

Position Transducers up to 750 mm

LWG Series



Special features

- twin-bearing actuating rod
- mountable over backlash-free pivot heads with a large angle of free movement (up to $\pm 12.5\%$)
- outstanding linearity
- resolution better than 0.01 mm
- life (depending on application) up to 50 million movements
- protection class IP 65

The LWG series was designed for a wide range of demanding applications in the mechanical, vehicle, automation and robotics industries. Outstanding linearity and accurate measurement are achieved with a resistance element made of conductive plastic melded to a glass-fiber reinforced substrate.

The wiper system is mounted on the actuating rod and coupled free-of-backlash for a long life and trouble-free operation.

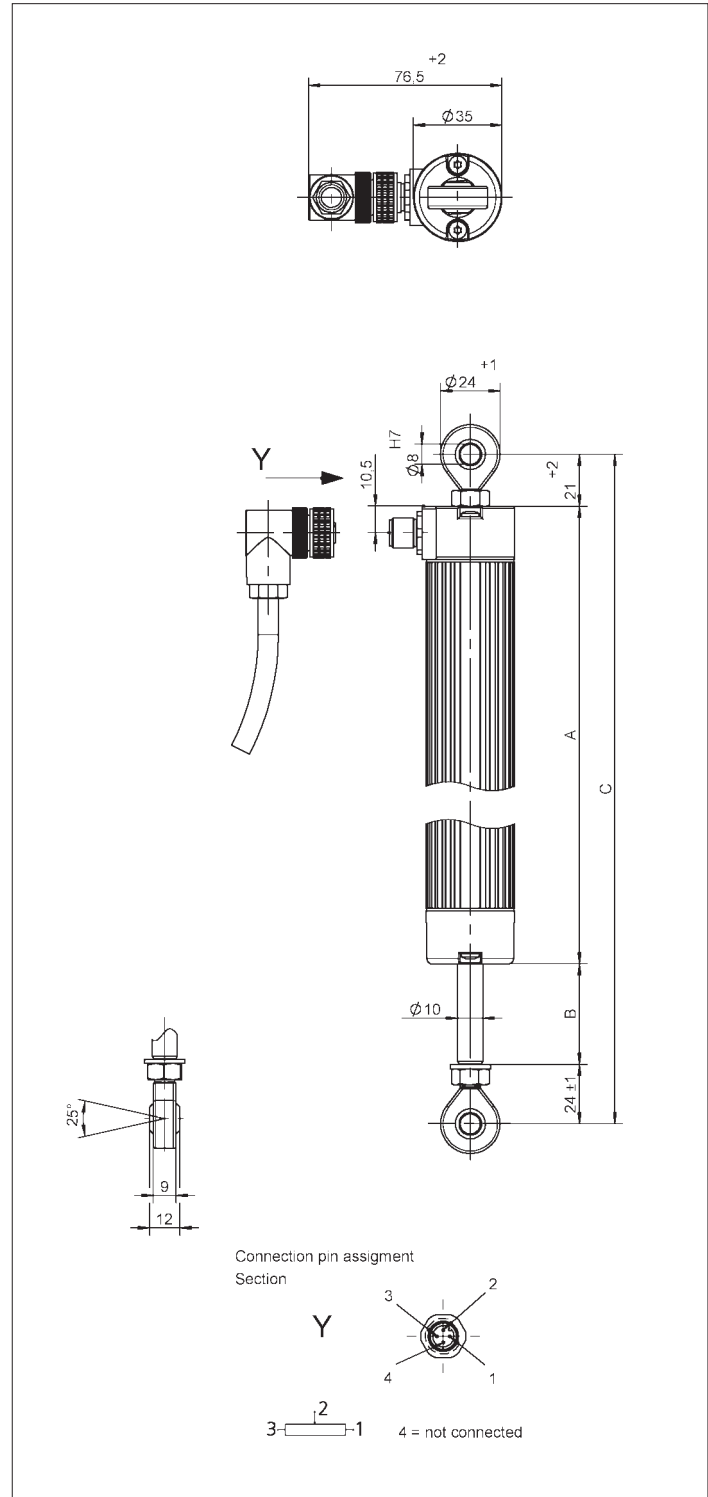
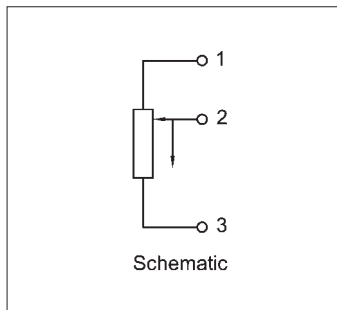

Description	
Housing	aluminum, anodized
Fixings	see drawing
Actuator	stainless steel, rotatable
Bearings	sleeve bearing
Resistance element	conductive plastic
Wiper assembly	precious metal multi-finger wiper, elastomer damped
Electrical connections	3-pole socket

Environmental Data		
Temperature range	-30...+100	°C
Vibration	5...2000 $A_{max} = 0.75$ $a_{max} = 20$	Hz mm g
Shock	50 11	g ms
Life	50 x 10 ⁶ (typical)	movem.
Operating speed	5	m/s max.
Protection class	IP 65 (DIN 400 50 / IEC 529)	

Type designations	LWG 75	LWG 100	LWG 150	LWG 225	LWG 300	LWG 360	LWG 450	LWG 500	LWG 600	LWG 750	
Electrical Data											
Defined electrical range	75	100	150	225	300	360	450	500	600	750	mm
Electrical stroke	76	102	152	228	304	366	457	508	610	762	mm
Nominal resistance	3	3	5	5	5	5	5	5	5	10	kΩ
Resistance tolerance	20										±%
Independent linearity	0.1	0.1	0.08	0.07	0.06	0.05	0.05	0.05	0.05	0.04	%
Repeatability	< 0.01										mm
Recommended operating wiper current	≤ 1										μA
Max. wiper current in case of malfunction	10										mA
Max. permissible applied voltage	42										V
Effective temperature coefficient of the output-to-applied voltage ration	typical 5										ppm/K
Insulation resistance (500 VDC, 1 bar, 2 s)	≥ 10										MΩ
Dielectric strength (50 Hz, 2 s, 1 bar, 500 VAC)	≤ 100										μA
Mechanical Data											
Body length (dimension A)	201	227	277	354	430	505	619	684	810	994	±2 mm
Mechanical stroke (dimension B)	79	105	155	231	307	368	460	510	612	764	±2 mm
Minimum distance between pivot heads (dimension C)	247	273	323	400	476	551	665	730	856	1040	mm
Operating force horizontal	3.6	3.7	4.0	4.5	4.9	5.2	5.7	6	6.6	7.5	N
vertical	7.4	7.6	8.0	8.7	9.3	9.8	10.6	11	11.9	13.2	N

Order designations	
Type	Art. no.
LWG 75	002459
LWG 100	002460
LWG 150	002461
LWG 225	002462
LWG 300	002464
LWG 360	002465
LWG 450	002466
LWG 500	002467
LWG 600	002468
LWG 750	002470

Other lengths on request

Recommended accessories

Process-controlled indicators
MAP...with display,
Signal conditioner MUP.../MUK...
for standardized output signals